

MFJ

Radio Interface

Model MFJ-5124K/Y



INSTRUCTION MANUAL

CAUTION: Read All Instructions Before Operating Equipment !

MFJ ENTERPRISES, INC.

300 Industrial Park Road
Starkville, MS 39759 USA
Tel: 662-323-5869 Fax: 662-323-6551

Contents

- Introduction..... 1
 - Front Panel..... 1
 - To Tuner 1
 - Power..... 1
 - To Radio 1
 - Jumper Settings..... 2
- Kenwood Radio Interface 3
 - Connections 3
 - Operation 4
- Yaesu Radio TUNER Interface..... 5
 - Connections for FT-100..... 5
 - Operation for FT-100..... 6
 - Connections for FT-857 or FT-897..... 6
 - Operation for FT-857 or FT-897..... 7
- Yaesu Radio CAT Interface..... 8
 - Connections for FT-100..... 8
 - Connections for FT-857 or FT-897..... 9
 - Connections for FT-847..... 10
 - Operation for Yaesu CAT Interface..... 10
- Firmware Version Number 11
- Technical Assistance..... 11
- Connector Pinout 12
- Schematic..... 13

THIS PAGE IS LEFT BLANK INTENTIONALLY

Introduction

The MFJ-5124 Radio Interface main unit contains all the electronics that allows users of AT-300 compatible Kenwood transceivers, FC-30 compatible Yaesu transceivers, and certain Yaesu transceivers with supported CAT system to connect to the MFJ-991, MFJ-993 and MFJ-994 *IntelliTuner*[™] Automatic Antenna Tuners. With this interface, DC power to the radio interface and the tuner is supplied by the radio, except FT-847 CAT. Using the appropriate cable and selecting the interface protocol via internal jumpers allow one-button automatic tuning operation with various Kenwood and Yaesu transceivers.

Front Panel

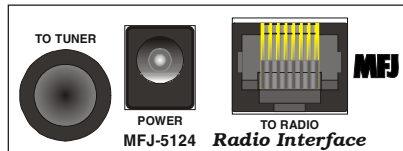

- **To Tuner:** The 3.5 mm stereo phone plug connects to the tuner's RADIO INTERFACE jack, and the 2.1 × 5.5 mm coaxial plug connects to the tuner's POWER jack.
- **Power:** Accepts a standard 2.1 × 5.5 mm coaxial plug with positive center and negative sleeve. The tuner requires 12 volts DC at up to 1 amp. The use of a regulated supply is not mandatory but is recommended for best performance. An optional 12 volts DC 1.5 amp power supply, the MFJ-1316, is available from MFJ Enterprises, Inc.

Most radios provide +13.8 volts through the radio's tuner port (Kenwood AT/ACC or Yaesu CAT/LINEAR) to the TO RADIO jack, so the POWER jack connection is rarely used. If the radio's tuner port does not have a power connection, such as the Yaesu FT-847 CAT connector, then connect a power supply to this connector. If the radio's tuner port has a power connection but cannot supply one amp of current, then remove the internal jumper JP3 and connect a power supply to this connector. Check your radio's operating manual.

WARNING: Do not apply voltages greater than 18 volts to this unit, or permanent damage to the unit and the tuner may result.

- **To Radio:** Accepts an 8-pin modular plug that connects the radio interface to a Kenwood AT/ACC or Yaesu CAT/LINEAR connector. Use proper cable for the various radios.

Jumper Settings

Two jumpers, JP1 and JP2, inside the MFJ-5124 are used to select the radio to interface with. To change these jumper settings:

1. Disconnect the MFJ-5124 from the radio and the tuner.
2. Open the MFJ-5124 case by removing the two screws on the bottom.
3. Configure jumpers JP1 and JP2 according to the following table to select the radio to interface with.

JP1	JP2	To Interface	Using
A	A	Kenwood (auto detected tuner) † such as TS-570S, etc.	MFJ-5124K (6-pin molex)
A	B	Kenwood (menu enabled tuner) such as TS-450S, TS-690S, etc.	MFJ-5124K (6-pin molex)
A	C	Firmware Version Number	N/A
B	A	Yaesu TUNER interface ‡ FT-100, FT-857, FT-897	MFJ-5124Y (8-pin mini DIN)
B	B	Reserved for future use.	N/A
B	C	Reserved for future use.	N/A
C	A	Yaesu CAT interface FT-100	MFJ-5124Y (8-pin mini DIN)
C	B	Yaesu CAT interface FT-857, FT-897	MFJ-5124Y (8-pin mini DIN)
C	C	Yaesu CAT interface § FT-847	MFJ-5124Y2 (DB-9)

† MFJ-5124K factory default.

‡ MFJ-5124Y factory default.

§ MFJ-5124Y2 factory default.

4. Close the MFJ-5124 case and secure with the two screws.
5. Refer to the appropriate section in this manual to connect the MFJ-5124 to the radio and the tuner.

Note: The Yaesu TUNER interface allows the use of the *radio's* (TUNE) key to initiate automatic tuning, whereas the Yaesu CAT interface uses the *tuner's* [TUNE] button to start automatic tuning.

Kenwood Radio Interface

The MFJ-5124K radio interface allows users of AT-300 compatible Kenwood transceivers to connect to the MFJ-991, MFJ-993 and MFJ-994 *IntelliTuner*™ Automatic Antenna Tuners. With this interface, DC power is supplied by the radio and control signals are connected between the radio and the tuner. The operator can then control the tuner with a single push of the [AT TUNE] button on the front panel of the radio. Supported Kenwood radios are TS-50S, TS-450S, TS-480HX, TS-570S, TS-690S, TS-850S, TS-870S, TS-2000, and any Kenwood radio that supports the Kenwood AT-300 tuner.

Note: The TS-480HX will automatically reduce its TX power to 100 watts maximum (25 watts AM) when the radio interface is used.

Connections

1. Insert the 3.5 mm stereo phone plug into the tuner's RADIO INTERFACE jack.
2. Insert the 2.1 x 5.5 mm coaxial power plug into the tuner's POWER jack.
3. Insert the 8-pin modular plug into the MFJ-5124's TO RADIO jack.
4. **Important:** *Make sure the DC power to the radio has been turned off. The radio does not fuse the DC power to the tuner, and damage to the radio can occur if the interface's power connection comes in contact with ground.*
5. Connect the 6-pin molex connector to the mating 6-pin molex connector, marked as AT or ACC, on the back of the Kenwood radio.
6. Push the [POWER] button on the tuner to the *in* position. When the radio is turned on, the tuner will also power on.
7. Some Kenwood radios automatically check to see if an external antenna tuner is connected during power on, such as the TS-570S (set jumper JP2 to the A position). This is the factory default setting. If both needles on the MFJ tuner keep bouncing (TURN ON RADIO appears on the MFJ-993) and do not go away, then move jumper JP2 to the B position.

For other Kenwood radios, the External Antenna Tuner menu in the radio menu system must be enabled, such as the TS-450S and the TS-690S (set jumper JP2 to the B position). If the MFJ tuner switches to bypass mode during power on, then move jumper JP2 to the A position because the radio is checking for a tuner presence during power on.

Refer to your radio's operating manual for accessing the menu system and preparing the AT-300 external antenna tuner operation. Use TS-450S and TS-690S as an example:

- a. Press and hold the [ENT] key while turning the power on.
- b. Rotate the M.CH/VFO CH control to select menu number 01 on the display.
- c. Press the [UP] or [DOWN] key to change the setting to "ON."
- d. Press the [CLR] key to return to normal operation.

Operation

The operation of the MFJ-5124K radio interface is similar to the operation of the AT-300 described in the Kenwood radio's operating manual.

1. Press and hold the [AT TUNE] button on the radio for one second to initiate automatic tuning process. The radio will automatically switch to CW mode, transmit a 10-watt carrier, and start the tuning process. When the tuning process is completed, the radio will stop transmitting, return to its previous mode and power setting.
2. Press the [AT TUNE] button on the radio quickly to bypass the tuner (some Kenwood radios, such as the TS-690S, do not have this bypass function) or to cancel tuning in progress.

Note the [TUNE] button on the tuner will not operate the Kenwood radio interface.

Yaesu Radio TUNER Interface

The MFJ-5124Y radio interface allows users of Yaesu FT-100, FT-857, FT-897, and FC-30 compatible Yaesu transceivers to connect to the MFJ-991, MFJ-993 and MFJ-994 *IntelliTuner*™ Automatic Antenna Tuners. With this interface, DC power is supplied by the radio and control signals are connected between the radio and the tuner. The operator can then control the tuner with a single push of the (TUNE) key on the front panel of the radio. Supported Yaesu radios are FT-100, FT-857, FT-897, and any Yaesu radio that supports the Yaesu FC-30.

Connections for FT-100

1. Before connecting the MFJ-5124 to your radio, follow the instructions in the radio's manual for installing the FC-20 automatic antenna tuner.
 - a. Press and hold in the [FUNC] key for ½ second to activate the Menu mode.
 - b. Rotate the SELECT knob to recall Menu #61 [TUNER/ATAS], and then rotate the MAIN DIAL to change the setting to "tunEr."
 - c. Press the [FUNC] key momentarily to save the new setting and exit to normal operation.
 - d. Turn the FT-100's power off, then on again, to re-initialize the radio regarding the tuner status.
2. Turn the radio off.
3. Insert the 3.5 mm stereo phone plug into the tuner's RADIO INTERFACE jack.
4. Insert the 2.1 x 5.5 mm coaxial power plug into the tuner's POWER jack.
5. Insert the 8-pin modular plug into the MFJ-5124's TO RADIO jack.
6. **Important:** *Make sure the DC power to the radio has been turned off. The radio does not fuse the DC power to the tuner, and damage to the radio can occur if the interface's power connection comes in contact with ground.*
7. Connect the 8-pin mini DIN connector to the mating 8-pin mini DIN connector at the end of the BAND DATA cable pigtail on the back of the radio.
8. Push the [POWER] button on the tuner to the *in* position. When the radio is turned on, the tuner will also power on.

Operation for FT-100

The operation of the MFJ-5124Y radio interface is similar to the operation of the FC-20 described in the Yaesu radio's operating manual.

1. Turn on the radio and press the [FUNC] key, as needed, to recall Operating Function Row 7 [MTR, TUN, PRO, VOX].
2. Press the [B](TUN) key on the radio for ½ second to turn the FC-20 function on; the "TUN" indicator will appear bolded on the radio's display.
3. Press and hold in the [B](TUN) key on the radio to initiate automatic tuning. The radio will automatically transmit a low-power carrier and start the tuning process. When tuning is completed, the radio will stop transmitting and you will be ready for operation on this frequency. Press the [B](TUN) key again to cancel tuning in progress.

Note the [TUNE] button on the tuner will not operate the Yaesu radio's TUNER interface.

Connections for FT-857 or FT-897

1. Before connecting the MFJ-5124 to your radio, follow the instructions in the radio's manual for installing the FC-30 automatic antenna tuner. For the following procedure, use the [FUNC] key and the SELECT knob on the FT-857, or use the [F] key and the MEM/VFO CH knob on the FT-897.
 - a. Press and hold in the [FUNC] or [F] key for one second to activate the Menu mode.
 - b. Rotate the SELECT or MEM/VFO CH knob to recall Menu Mode #001 [EXT MENU], and then rotate the DIAL to change the setting to "ON" to enable the extended Menu Mode.
 - c. Rotate the SELECT or MEM/VFO CH knob to recall Menu Mode #020 [CAT/LIN/TUN], and then rotate the DIAL to change the setting to "TUNER."
 - d. Press and hold in the [FUNC] or [F] key for one second to save the new setting and exit to normal operation.
 - e. Turn the radio off, then on again. Do not connect the MFJ-5124Y before changing the Menu Mode #020 [CAT/LIN/TUN].
 - f. Press and hold in the [FUNC] or [F] key for one second to activate the Menu mode.

- g. Rotate the SELECT or MEM/VFO CH knob to recall Menu Mode #085 [TUNER/ATAS], and then rotate the DIAL to change the setting to "TUNER."
 - h. Press and hold in the [FUNC] or [F] key for one second to save the new settings and exit to normal operation.
2. Turn the radio off.
 3. Insert the 3.5 mm stereo phone plug into the tuner's RADIO INTERFACE jack.
 4. Insert the 2.1 x 5.5 mm coaxial power plug into the tuner's POWER jack.
 5. Insert the 8-pin modular plug into the MFJ-5124's TO RADIO jack.
 6. **Important:** *Make sure the DC power to the radio has been turned off. The radio does not fuse the DC power to the tuner, and damage to the radio can occur if the interface's power connection comes in contact with ground.*
 7. Connect the 8-pin mini DIN connector to the mating 8-pin mini DIN connector, marked as CAT/LINEAR, on the back of the radio.
 8. Push the [POWER] button on the tuner to the *in* position. When the radio is turned on, the tuner will also power on.

Operation for FT-857 or FT-897

The operation of the MFJ-5124Y radio interface is similar to the operation of the FC-30 described in the Yaesu radio's operating manual.

1. Turn on the radio. Press the [FUNC] or [F] key, then rotate the SELECT or MEM/VFO CH knob to recall Multi Function Row "k" [TUNE, DOWN, UP].
2. Press the [A](TUNE) key on the radio to turn the FC-30 function on; the "TUNE" or "TUNR" indicator will appear on the radio's display.
3. Press and hold in the [A](TUNE) key on the radio to initiate automatic tuning. The radio will automatically transmit a low-power carrier and start the tuning process. When tuning is completed, the radio will stop transmitting and you will be ready for operation on this frequency. Press the [A](TUNE) key again to cancel tuning in progress.

Note the [TUNE] button on the tuner will not operate the Yaesu radio's TUNER interface.

Yaesu Radio CAT Interface

The MFJ-5124Y radio interface also allows users of certain Yaesu transceivers that have an 8-pin mini DIN CAT port, such as the FT-100, FT-857 and FT-897, to connect to the MFJ-991, MFJ-993 and MFJ-994 *IntelliTuner™* Automatic Antenna Tuners. The MFJ-5124Y2 radio interface connects to Yaesu transceivers that have a DB-9 CAT port, such as the FT-847. With this interface, DC power (except FT-847) is supplied by the radio and control signals are connected between the tuner and the radio. The operator can then control the tuner and the radio with the [TUNE] button on the front panel of the tuner.

Connections for FT-100

1. Before connecting the MFJ-5124 to your radio, setup the radio's CAT.
 - a. Press and hold in the [FUNC] key for ½ second to activate the Menu mode.
 - b. Rotate the SELECT knob to recall Menu #61 [TUNER/ATAS], and then rotate the MAIN DIAL to change the setting to "oFF."
 - c. Press the [FUNC] key momentarily to save the new setting and exit to normal operation.
2. Turn the radio off.
3. Insert the 3.5 mm stereo phone plug into the tuner's RADIO INTERFACE jack.
4. Insert the 2.1 x 5.5 mm coaxial power plug into the tuner's POWER jack.
5. Insert the 8-pin modular plug into the MFJ-5124's TO RADIO jack.
6. **Important:** *Make sure the DC power to the radio has been turned off. The radio does not fuse the DC power to the tuner, and damage to the radio can occur if the interface's power connection comes in contact with ground.*
7. Connect the 8-pin mini DIN connector to the mating 8-pin mini DIN connector at the end of the BAND DATA cable pigtail on the back of the radio.
8. Push the [POWER] button on the tuner to the *in* position. When the radio is turned on, the tuner will also power on.
9. For operating procedure, refer to "Operation for Yaesu CAT Interface" on page 10.

Connections for FT-857 or FT-897

1. Before connecting the MFJ-5124 to your radio, setup the radio's CAT. For following steps, use the [FUNC] key and the SELECT knob on the FT-857, or use the [F] key and the MEM/VFO CH knob on the FT-897.
 - a. Press and hold in the [FUNC] or [F] key for one second to activate the Menu mode.
 - b. Rotate the SELECT or MEM/VFO CH knob to recall Menu Mode #001 [EXT MENU], and then rotate the DIAL to change the setting to "ON" to enable the extended Menu Mode.
 - c. Rotate the SELECT or MEM/VFO CH knob to recall Menu Mode #085 [TUNER/ATAS], and then rotate the DIAL to change the setting to "OFF."
 - d. Rotate the SELECT or MEM/VFO CH knob to recall Menu Mode #020 [CAT/LIN/TUN], and then rotate the DIAL to change the setting to "CAT."
 - e. Rotate the SELECT or MEM/VFO CH knob to recall Menu Mode #019 [CAT RATE], and then rotate the DIAL to change the setting to "4800bps."
 - f. Press and hold in the [FUNC] or [F] key for one second to save the new settings and exit to normal operation.
2. Turn the radio off.
3. Insert the 3.5 mm stereo phone plug into the tuner's RADIO INTERFACE jack.
4. Insert the 2.1 x 5.5 mm coaxial power plug into the tuner's POWER jack.
5. Insert the 8-pin modular plug into the MFJ-5124's TO RADIO jack.
6. **Important:** *Make sure the DC power to the radio has been turned off. The radio does not fuse the DC power to the tuner, and damage to the radio can occur if the interface's power connection comes in contact with ground.*
7. Connect the 8-pin mini DIN connector to the mating 8-pin mini DIN connector, marked as CAT, on the back of the radio.
8. Push the [POWER] button on the tuner to the *in* position. When the radio is turned on, the tuner will also power on.
9. For operating procedure, refer to "Operation for Yaesu CAT Interface" on page 10.

Connections for FT-847

1. Before connecting the MFJ-5124 to your radio, setup the radio's CAT.
 - a. Press the [MENU] key momentarily to activate the Menu mode.
 - b. Rotate the SUB-TUNE knob to recall Menu #37 [CAT RATE], and then rotate the MEM/VFO CH knob to change the setting to "4800."
 - c. Press the [MENU] key momentarily to save the new setting and exit to normal operation.
2. Turn the radio off.
3. Insert the 3.5 mm stereo phone plug into the tuner's RADIO INTERFACE jack.
4. Insert the 2.1 x 5.5 mm coaxial power plug into the tuner's POWER jack.
5. Insert the 8-pin modular plug into the MFJ-5124's TO RADIO jack.
6. **Important:** *Make sure the DC power to the radio has been turned off.*
7. Connect the DB-9 connector to the mating DB-9 connector, marked as CAT, on the back of the radio.
8. The FT-847 does not have a DC power connection on its CAT port. Connect a 12 volts DC 1 amp power supply, such as the MFJ-1316, to the MFJ-5124's POWER jack. This will supply power to the MFJ-5124 and the tuner.
9. See "Operation for Yaesu CAT Interface" below for operation.

Operation for Yaesu CAT Interface

The operation of the MFJ-5124Y/Y2 CAT interface is simple.

1. Turn on the radio. For the MFJ-5124Y2, turn on the tuner.
2. Press and hold the [TUNE] button on the tuner for 0.5 to 2 seconds to start the automatic tuning. The radio will switch to AM mode, transmit a carrier, and start the tuning process. When the tuning process is completed, the radio will stop transmitting and return to its previous mode. Press the [TUNE] button on the tuner briefly will place the tuner into bypass mode.

Note the (TUNE) key on the radio will not operate the Yaesu radio's CAT interface.

Firmware Version Number

The firmware version number of the MFJ-5124 can be read using the analog meter on the MFJ-991/993/994 auto tuners via the interface cable. To obtain the firmware version number, place jumper JP1 on the “A” position, jumper JP2 on the “C” position, and then turn on the radio’s power. After the initial bouncing of both needles on the auto tuner, the reflected needle will bounce repetitively with approximately five seconds pause between intervals. The number of bounces within each interval indicates the version number. For example, two bounces of the reflected needle represent firmware version number 2.

Technical Assistance

If you have any problem with this unit first check the appropriate section of this manual. If the manual does not reference your problem or your problem is not solved by reading the manual, you may call *MFJ Technical Service* at 662-323-0549 or the *MFJ Factory* at 662-323-5869. You will be best helped if you have your unit, manual and all information on your station handy so you can answer any questions the technicians may ask.

You can also send questions by mail to MFJ Enterprises, Inc., 300 Industrial Park Road, Starkville, MS 39759; by facsimile (FAX) to 662-323-6551; or by email to techinfo@mfjenterprises.com. Send a complete description of your problem, an explanation of exactly how you are using your unit, a complete description of your station, and the unit’s firmware version number.

Connector Pinout

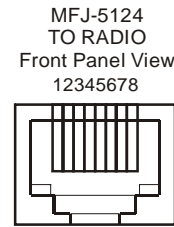

- ① +13.8 V DC input (1 A)
- ② +13.8 V DC input (1 A)
- ③ +13.8 V DC input (1 A)
- ④ Ground
- ⑤ Ground
- ⑥ TT/TX
- ⑦ TX INH
- ⑧ TS/RX

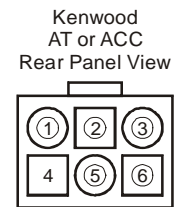

- ① Pin 1 (Ground) connects to pin 4 of the TO RADIO plug.
- ② Pin 2 (TT) connects to pin 6 of the TO RADIO plug.
- ③ Pin 3 (Ground) connects to pin 5 of the TO RADIO plug.
- ④ Pin 4 is not connected.
- ⑤ Pin 5 (TS) connects to pin 8 of the TO RADIO plug.
- ⑥ Pin 6 (+13.8V) connects to pins 2 and 3 of the TO RADIO plug.

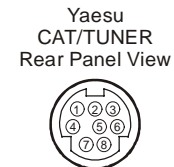

- ① Pin 1 (TX INH) connects to pin 7 of the TO RADIO plug.
- ② Pin 2 is not connected.
- ③ Pin 3 (SENSE) connects to pin 5 of the TO RADIO plug.
- ④ Pin 4 (TX) connects to pin 6 of the TO RADIO plug.
- ⑤ Pin 5 (RX) connects to pin 8 of the TO RADIO plug.
- ⑥ Pin 6 (Ground) connects to pin 4 of the TO RADIO plug.
- ⑦ Pin 7 is not connected.
- ⑧ Pin 8 (+13.8V) connects to pin 3 of the TO RADIO plug.

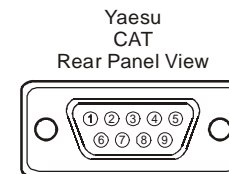

- ① Pin 1 is not connected.
- ② Pin 2 (TX) connects to pin 6 of the TO RADIO plug.
- ③ Pin 3 (RX) connects to pin 8 of the TO RADIO plug.
- ④ Pin 4 is not connected.
- ⑤ Pin 5 (Ground) connects to pins 4 and 5 of the TO RADIO plug.
- ⑥ Pin 6 is not connected.
- ⑦ Pin 7 is not connected.
- ⑧ Pin 8 is not connected.
- ⑨ Pin 9 is not connected.

Schematic

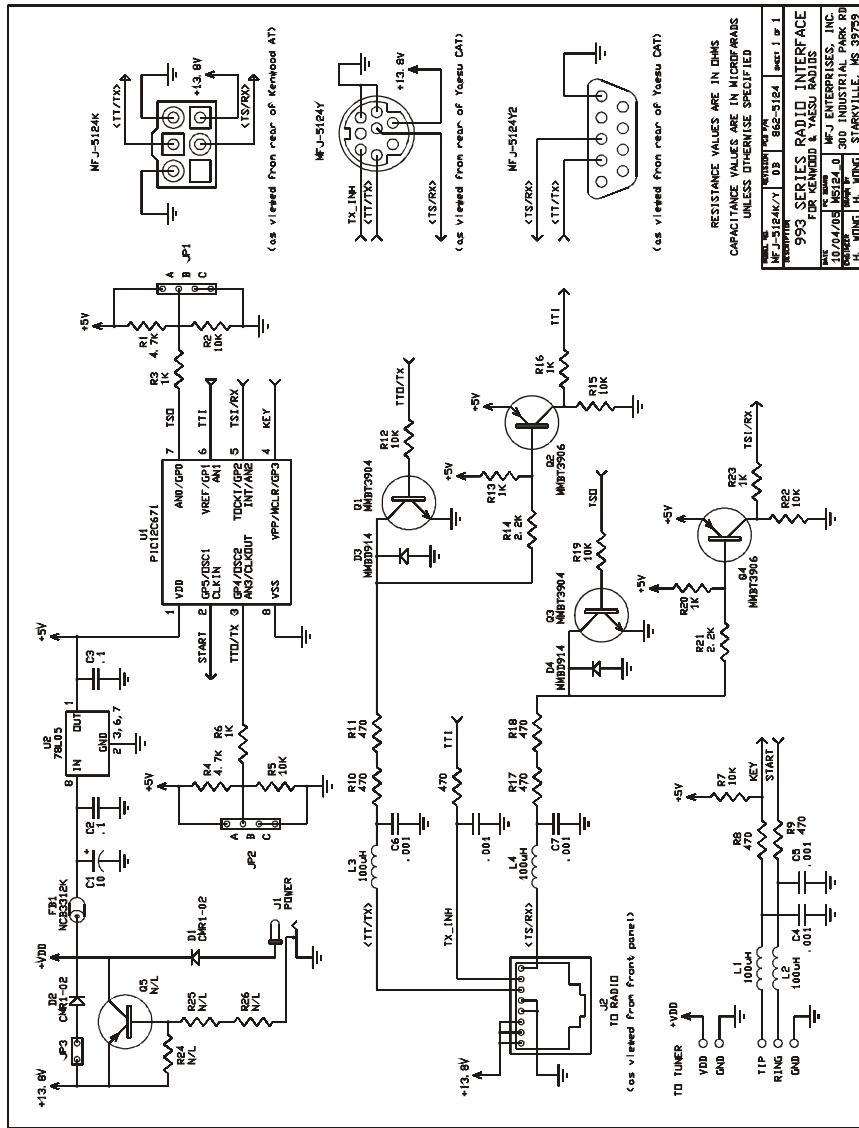

Note

LIMITED 12 MONTH WARRANTY

MFJ Enterprises, Inc. warrants to the original owner of this product, if manufactured by MFJ Enterprises, Inc. and purchased from an authorized dealer or directly from MFJ Enterprises, Inc. to be free from defects in material and workmanship for a period of 12 months from date of purchase provided the following terms of this warranty are satisfied:

1. The purchaser must retain the dated proof-of-purchase (bill of sale, canceled check, credit card or money order receipt, etc.) describing the product to establish the validity of the warranty claim and submit the original or machine reproduction of such proof of purchase to MFJ Enterprises, Inc. at the time of warranty service. MFJ Enterprises, Inc. shall have the discretion to deny warranty without dated proof-of-purchase. Any evidence of alteration, erasure, or forgery shall be cause to void any and all warranty terms immediately.
2. MFJ Enterprises, Inc. agrees to repair or replace at MFJ's option without charge to the original owner any defective product under warrantee provided the product is returned postage prepaid to MFJ Enterprises, Inc. with a personal check, cashiers check, or money order for \$7.00 covering postage and handling.
3. This warranty is NOT void for owners who attempt to repair defective units. Technical consultation is available by calling the Service Department at 662-323-0549 or the MFJ Factory at 662-323-5869.
4. This warranty does not apply to kits sold by or manufactured by MFJ Enterprises, Inc.
5. Wired and tested PC board products are covered by this warranty provided only the wired and tested PC board product is returned. Wired and tested PC boards installed in the owner's cabinet or connected to switches, jacks, or cables, etc. sent to MFJ Enterprises, Inc. will be returned at the owner's expense unrepaired.
6. Under no circumstances is MFJ Enterprises, Inc. liable for consequential damages to person or property by the use of any MFJ products.
7. Out-of-Warranty Service: MFJ Enterprises, Inc. will repair any out-of-warranty product provided the unit is shipped prepaid. All repaired units will be shipped COD to the owner. Repair charges will be added to the COD fee unless other arrangements are made.
8. This warranty is given in lieu of any other warranty expressed or implied.
9. MFJ Enterprises, Inc. reserves the right to make changes or improvements in design or manufacture without incurring any obligation to install such changes upon any of the products previously manufactured.
10. All MFJ products to be serviced in-warranty or out-of-warranty should be addressed to:

**MFJ Enterprises, Inc.
300 Industrial Park Road
Starkville, Mississippi 39759 USA**

and must be accompanied by a letter describing the problem in detail along with a copy of your dated proof-of-purchase.

11. This warranty gives you specific rights, and you may also have other rights which vary from state to state.



MFJ ENTERPRISES, INC.
300 Industrial Park Road
Starkville, MS 39759 U.S.A.

MFJ-5124K/Y Manual
Version 0D
Printed In U.S.A. 02/2006